

WIKĘD 

CATALOG



PVC AND ALU
WINDOWS & DOORS

— **27** YEARS —
WITH YOU

INTRODUCTION

The WIKĘD company is a Polish manufacturer of windows and external doors for houses and flats. The factory located in Luzino in northern Poland currently employs over 400 people. The brand was founded in 2002 by two friends, enthusiasts of construction art - Grzegorz Wiśniewski and Rafał Kędziora. WIKĘD started with the production of PVC windows, and currently it is the leader of the external door market in Poland, receiving numerous titles and awards.

By choosing WIKĘD windows and doors, you receive the assurance of safety for many years and a guarantee of high quality craftsmanship. For production, we use only proven technologies and the best materials, which in combination with modern machinery, constantly introduced improvements as well as following and creating the latest trends allows the company to fit into the taste and needs of the most demanding customers.

This catalog presents a number of new products, about which you can receive more information at our numerous distribution and sales points. Thank you for your trust and motivation for further development.



Introduction	2
New items	4
Colors	7
Worth knowing: What makes WIKED windows special	9
PVC windows & doors	14
ALU windows & doors	30
Patterned Glass and Custom Windows	42
PVC fittings	43
Terrace doors	47
Additional equipment	48



NEW PVC

ADDITIONAL EQUIPMENT

GLASS BALUSTRADE

A **glass balustrade** is a modern solution that offers a solid structure and aesthetic appearance. The glass barrier does not limit the view outside the window, which allows more light to flow into the house. The product is resistant to wind pressure, increasing protection against wind.

We offer several colors: RAL 9016, RAL 8017, RAL 9005, RAL 9006, RAL 1036, RAL 7016, RAL 9007. The glass from which the barrier is made is 13.52 mm thick and made of tempered safety glass ESG/VSG 66.2. Standard glass (clear) is available. This solution is suitable when it is not possible to install a traditional balcony.

Our glass balustrade is safe and its durability was affirmed in terms of pressure, extensibility and fastening durability. It is mounted directly onto the window, which means that it does not have to be installed onto the wall.

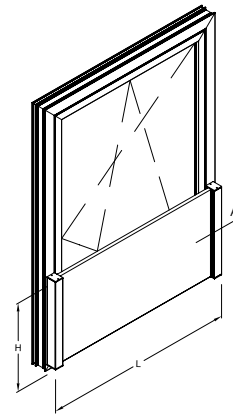

AVAILABLE COLORS

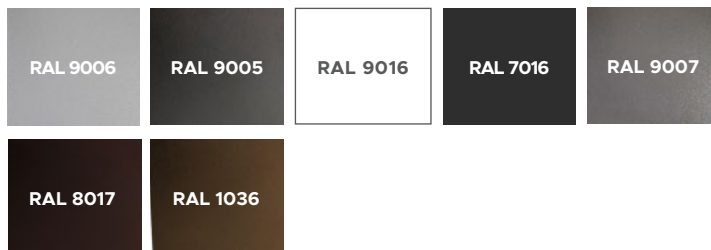

Glass balustrade cross-section

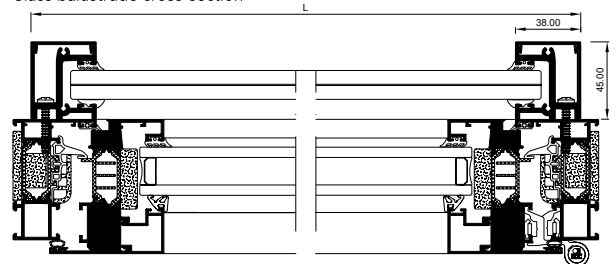

SLIDING SYSTEM

LEGEND SLIDE

Discover the modern **Legend Slide** sliding system. The five-chamber structure ensures excellent thermal insulation (U_w up to $0.77 \text{ W/m}^2\text{K}$) and water and wind tightness up to class C3. Additional security is provided by anti-burglary fittings that effectively protect the house against burglary. Thanks to a wide selection of glass packages (12-54 mm), you can adjust the system to your needs. Slim rebate with a dimension of 9 mm gives the profile a modern look. The Leaf moves smoothly and effortlessly, ensuring comfortable use.

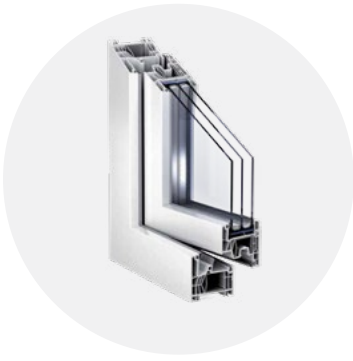

**WINDOW SYSTEM****TROCAL 76 MD**

Thanks to the unique six-chamber structure, the **Trocal 76 MD** system stands out with the highest thermal insulation parameters - U_f value up to 1.0 W/(m²K). Windows in this system can be equipped with glass packets from 16 mm to 48 mm thick. This system, with the use of special glass panes, guarantees optimal protection against noise coming from the outside up to 48 dB.

WINDOW SYSTEM**TROCAL 76 AD**

The Trocal 76 AD system meets the current requirements, but above all the parameters of the future - from the appearance and shape of the profiles, through static durability, functionality, to thermal insulation with a U_f value of up to 1.1 W/(m²K). Windows in this system can be equipped with glass packets from 16 mm to 48 mm thick. This system, with the use of special glass panes, also guarantees optimal protection against noise coming from the outside up to 47 dB.

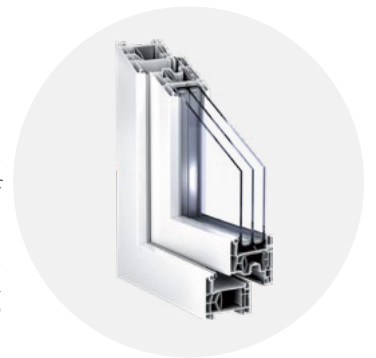
**TERMO FRAME-EXTENDER FOR INSTALLATION**

PVC frame extender filled with tough polyurethane foam with a closed chamber construction equipped with an additional flex resistant seal. Thanks to the special shape of the profile, this extender allows you to make a correct, tight and warm connection during the installation of pvc windows. Termo extenders can be joined during installation in place of standard extenders. Available only for Veka systems.

**Termo extender properties::**

Transportation – secure transport even very large and heavy terrace doors and windows if used as as transport strip

Double stand – increased durability and availability of attachment to other items in accordance with manufacturer's instructions

System click – is ensured by a special polyurethane seal

Airtightness of the connection, którą zapewnia specjalna uszczelka z poliuretanu

The even surface of the thermo-extender strip matched to the width of the window frame mounting legs allows for precise adjustment of the internal and external window sills



COLORS

SPECTRAL COLOR PALETTE

Perfectly matte, velvet surfaces, soft to the touch. Choose one of the colors of the Spectral palette: anthracite ultframett, platinum gray ultframett, umber ultframette, graphite black ultframett, milky white ultframett, dark green ultframett, monumental green ultframett, navy blue ultframett, VE-KA-white ultframett, sepia brown ultframett, wine red ultframett, oak tender white ultra-matt, tender oak antique ultra-matt and oak tender gray ultra-matt

EXPANSION TAPE FOR EXTENSIONS INSTALLED BEFORE SHIPMENT

Regardless of the selected PVC system, you get an additional option to choose an expanding tape that maintains tensile strength even at low temperatures.



INSULATING SPACER FRAME IN BETWEEN GLASS PANES

ULTIMATE SWISSPACER WARM SPACER FRAME



The range of warm spacer frames has been extended with the ULTIMATE frame, which provides an impressively low thermal conductivity coefficient at the edge of the glass unit and, according to globally recognized guidelines, is one of the best warm spacer frames in the world. Appropriately low values of the U_w coefficient for windows and facades can be obtained thanks to this frame. It grants additional energy savings for users. **This frame is available in our offer in black RAL 9005.**

SYSTEM PSK

HANDLE AND COVER FOR PSK

We have added a black handle and cover to the PSK system, which will add a unique style to your windows and allow you to match the windows to your interior.



PVC DOORS AND WINDOWS COLORS

Bearing in mind the very dynamic changes in trends in the construction industry, we are constantly expanding the available range of colors, both wood-like and metallic. Our palette includes basic and complementary colors - for an additional fee.

BASIC COLORS

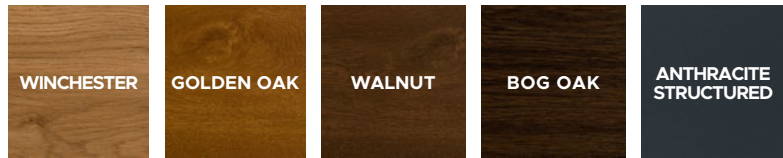

COMPLEMENTARY COLORS

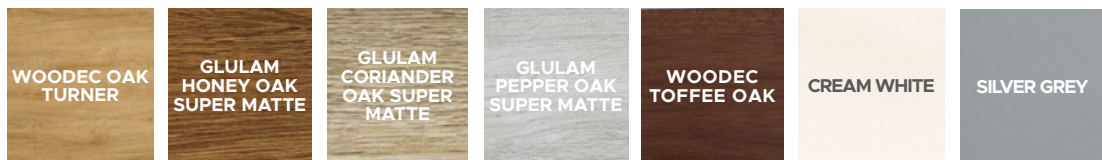
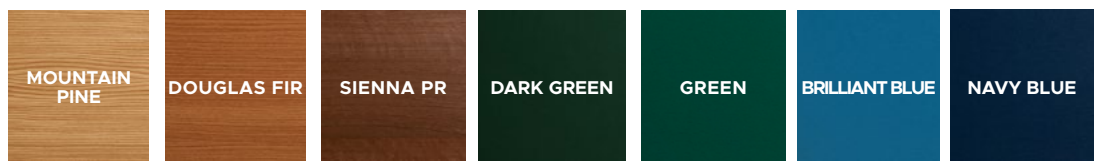

Other colors also available. Colors and patterns are for illustrative purposes only and may differ from the actual ones.
 * Matte Black color is not available for lift and slide doors.

SPECTRAL COLORS FOR PVC DOORS AND WINDOWS

Perfectly matte surfaces of PVC profiles are velvety and delicate to the touch. They have high resistance to mechanical damage and adverse weather conditions.

SPECTRAL COLORS

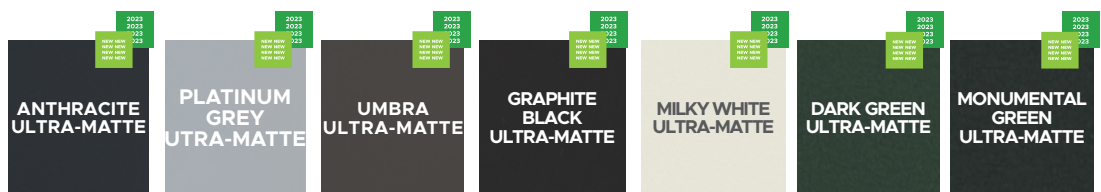



BICOLOR

DIFERENT COLORS FOR INSIDE AND OUTSIDE OF THE WINDOW.



MIXCOLOR

COMBINATION IN THE STYLE YOU LIKE. COLORS CAN BE COMBINED. FRAME AND SASH IN TWO DIFFERENT COLORS



ALU DOORS AND WINDOWS COLORS

BASIC COLORS

RAL 9006

RAL 9005

RAL 9016

RAL 7016

COMPLEMENTARY COLORS

DORATO

PINE

MAHOGANY

ROSEWOOD

WALNUT

CHERRY

ANTIQUE OAK

OLD OAK

WINCHESTER

ANY RAL
COLOR



GOOD WINDOWS ARE NOT ONLY MODERN DESIGN. GET TO KNOW THEIR FEATURES!

Good to know:



9

WHAT MAKES WIKĘD WINDOWS SPECIAL

SEAL COLOR PICKED TO THE WINDOW

products, you can choose the color of the gasket: gray, caramel or black. In combination with the selected veneer, it makes the finished product more attractive and affects its harmonious appearance.

Comes as standard - except for white.

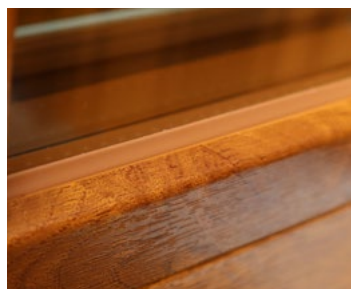

EXTENSIVE FITTING SYSTEM THAT INCREASES SECURITY AND AIRTIGHTNESS OF WINDOWS

An essential element for modern windows. Fittings have a great impact on the functionality, durability, failure-free and long-term use of our windows. Our windows have as standard:

- Blocked incorrect position of the handle - integrated with the sash lift; preventing accidental detachment of the sash from the hinges.
- Hinges adjustable in 3 planes.
- Pins with adjustable clamping force - allowing to increase the tightness of the window.
- Micro-ventilation - allowing to control the amount of air exchanged in the room, possible thanks to an additional position of the handle in the tilt and turn sash.
- 2 security pins as standard in each sash, making it difficult to lever the sash

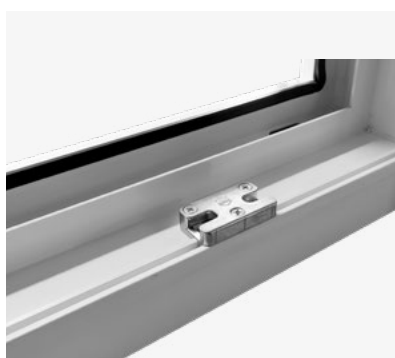
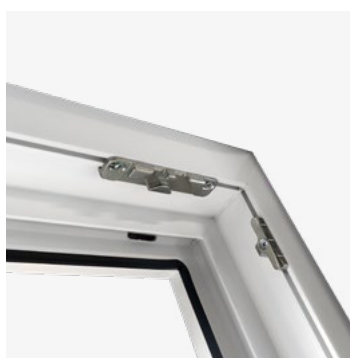
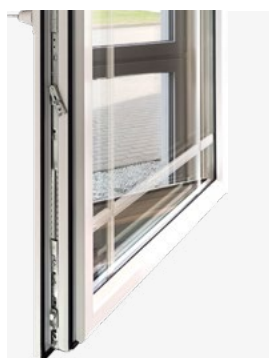

APPROPRIATE STEEL REINFORCEMENTS

The window after installation, regardless of the season, is constantly subjected to various factors affecting the durability of its structure. The profile made of reinforced galvanized steel with a thickness of 1.5 to 3 mm (selected depending on the size of the window) guarantees strength and stability of the window structure. Comes as standard.





ACCESSORIES

SECURITY FITTINGS IN CLASS WK1 OR WK2

Additional security latches and a handle with a key, protecting against manual break-in, kicking and tool assisted attacks (hammer, screwdriver, etc.) [Option for an extra charge.](#)



FITTINGS

REINFORCED LOWER HINGE

The use of a hinge with thicker and longer pins in the sash guarantees its stability and reliability in operation. A new pin, 23 mm long and 5 mm in diameter, passes through the sash chambers, stabilizing the position of the hinge. [Comes as standard.](#)

COLORED WINDOW PROFILE CORE

The core - the element of PVC joinery that is visible after opening the window, is available in white, caramel, dark brown and graphite. In combination with the selected double-sided veneer and the appropriate color of the gasket, it affects the color uniformity of the product. [Comes as standard.](#)

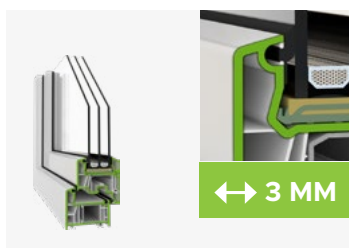
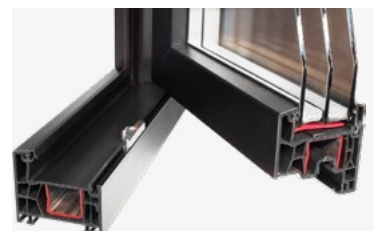

A-CLASS PROFILES

The profiles used for the production of WIKED windows are made in the highest class - A, in accordance with the PN-EN 12608 standard. The characteristic feature of class A is the thickness of the outer walls - 3mm. This is a key parameter for optimal protection of the household against cold and noise, while ensuring stability and durability of the windows. [Occurs only in VEKA systems](#)

SEAMLESS WELD AS STANDARD

Modern machinery park allows us to obtain welds of vertical and horizontal elements with a practically invisible bead (connection). The produced PVC joinery gains an attractive, modern look, and the corners perfectly match the internal glazing beads. In addition, the care of window joinery is much easier. Bead-free welding is a perfectly coordinated composition, which looks particularly attractive in wood-like colors. [Comes as standard.](#)





WHAT MAKES WIKĘD WINDOWS SPECIAL

HIDDEN HINGES

Elegance and safety, i.e. hinges hidden in the window sash, are a great choice for demanding customers. A good fit of the hinge elements in the frame of the sash and the frame hides the hinge in a sophisticated way. Thanks to their design, they ensure the simplicity of adjustment, and at the same time they ennoble the appearance of the windows and make it easier to keep them clean. [Option for an additional fee.](#)

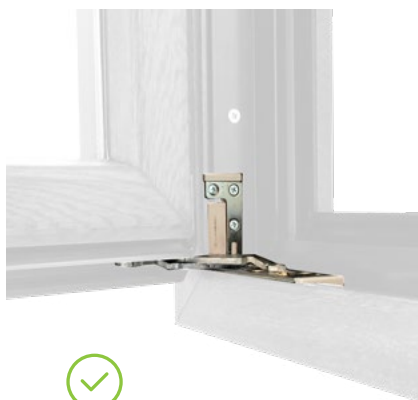

TRIPLE SEAL SYSTEM

Two- and three-seal solutions are used in PVC windows. Gaskets are installed by pressing them into the slots of the profile. In the system with two gaskets, one of the gaskets is mounted around the perimeter of the frame, the other on the window leaf pad. In triple-seal windows, an additional seal is placed in the middle part of the frame in contact with the window leaf. It has a positive effect on its air-tightness - it allows for better heat retention in the room and has a positive effect on reducing the noise level from the outside. [Standard for some systems](#)

SUB-THRESHOLD EXTENSIONS

In order for the windows to please you for many years, their assembly should be carried out in such a way as to eliminate possible thermal bridges (frosting) and to ensure the stability of the entire structure. An element that should be part of every balcony window is the sub-threshold extension. It guarantees stable seating of the entire structure, which has a very significant impact on the durability and longevity of the assembly. The WIKĘD offer includes extensions made of hardened expanded polystyrene (dimensions from 70-250 mm) and PVC in various heights dedicated to specific lines. Possibility of installing sub-threshold extensions at the production stage. [Option for an additional fee.](#) It is possible to install PVC extensions and seal their connection with an expanding tape at the production stage.

HARDENED EXPANDED POLYSTYRENE



PVC



EXPANSION TAPE FOR EXTENSIONS MOUNTED DURING PRODUCTION STAGE

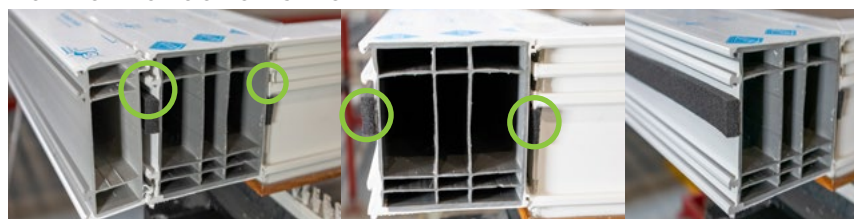



Good to know:

WHAT MAKES WIKĘD WINDOWS SPECIAL



GOOD WINDOWS ARE NOT ONLY MODERN DESIGN. GET TO KNOW THEIR FEATURES!

COMPATIBILITY OF WINDOW AND DOOR COLORS

WIKĘD products are a harmony of color. Choice of window color is one of the most important decisions when designing the aesthetic appearance of a building. Thanks to a consistent color palette, you can unify the doors and windows at home. Comes as standard.

CHECK OUR OFFER OF EXTERIOR DOORS FOR HOUSES AND APARTMENTS





TWO CHAMBER GLAZING

The wider the glazing unit, the better the thermal parameters, hence the popularity of a three-pane option. However, not every insulating glass unit has the same thermal parameters. The width of the glazing unit is decisive, and above all the width between the panes and the material from which it was made. In combination with the appropriate profile, we create windows that meet various preferences and meet the thermal requirements of tomorrow, today.



COLORS AVAILABLE
FOR WARM
SPACER FRAMES

WARM SPACER FRAMES

To ensure optimal properties of our windows, remember about warm spacer frames between the panes. They are made of a special material with incomparably better thermal parameters than standard - aluminum. The use of such a frame improves the thermal insulation of the edges of the panes, which increases the temperature in this area and significantly reduces the risk of temporary condensation there. This minimizes the possibility of condensation on the edges of the glazing on the inside.

WARM WINDOW SILLS AND WARM INSTALLATION

Warm windowsills are nothing more than under-window profiles, most often made of hard XPS polystyrene. Their use improves thermal isolation of the room - by eliminating possible blow-throughs and the penetration of water between the window and the sill. Together with warm installation methods, they reduce thermal bridges, moisture and blow-throughs.



CARE AND USE

Under the influence of time and weather conditions, the film protecting the windows vulcanizes, thus making it difficult to remove it later, therefore, after completing the assembly work, it should be immediately peeled off from the PVC profiles. As part of window maintenance, clean them with a soft cloth and a neutral detergent. This will ensure durability and proper appearance for many years. Printed instructions for use and care are included with each order.

A modern building facade featuring a mix of materials. The upper portion is constructed from red brick, while the lower portion is a smooth, light-colored finish. Large, dark-framed windows are prominent, reflecting the sky and surrounding greenery. A semi-transparent dark red overlay covers the bottom half of the image, containing text.

The power of proven solutions

Window profiles and lift and slide windows.

A modern brick house with a prominent glass door and large windows. The house has a red brick upper section and a white lower section. A semi-transparent dark red overlay covers the lower half of the image, containing the text 'PVC DOORS AND WINDOWS'. The background shows a green lawn and trees.

PVC DOORS AND WINDOWS



Thermal transmittance from
 $U_w = 0,77 \text{ W}/(\text{m}^2\text{K})^*$



76 mm
Installation depth



European CE
compliance standard



LEGEND SLIDE

Legend Slide is a sliding door system. It has a slim design thanks to an extremely low profile thanks to the glazing mounted directly in the frame. Possibility of constructing the system in large sizes thanks to the stiffness of the central section.

Combined with specialized fittings, it guarantees ease of use. Leaf moves smoothly without requiring the user to exert too much effort. It lets in more light.

Recommended for the Legend Slide system are asymmetrical structures with a narrower sliding leaf and a wider fixed part.

COMFORT OF USE



Product properties

Easy to use

Slim design

High wind resistance

Thermal insulation, acoustics and waterproofness at a high level

More light

Thanks to anti-burglary fittings, it is protected against burglary

deceuninck

THE MOST IMPORTANT PARAMETERS

DEPTH	CHAMBERS	SEALS
76 mm	5	3

* Heat transfer coefficient for type A reference window with dimensions of 3000/1480 mm with glazing: $U_g=0,5$.





Thermal transmittance from
 $U_w = 0,76 \text{ W}/(\text{m}^2\text{K})^*$



Installation depth



European CE
compliance standard

INVESTMENT SYSTEM ADAPTED TO CURRENT STANDARDS

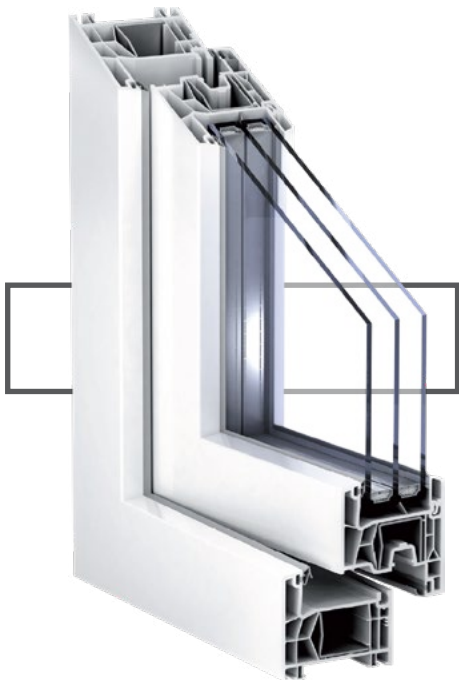

TROCAL 76 AD



By choosing the Trocal 76 AD window system, we shape our living space according to our individual preferences. The Trocal 76 AD system meets not only the current requirements, but above all the parameters of the future - from the appearance and shape of the profiles, through statics, functionality, to thermal and acoustic insulation.

Slim profiles, giving the impression of lightness, enable the implementation of large glazed areas and affect the optimal sunlight admittance of the room.

High quality, the use of modern, environmentally friendly and health-friendly raw materials as well as constant comfort of use ensure a long service life of the window.

Product properties

Trocal 76 AD window profiles are designed in such a way that it is possible to install special glass and special security fittings, achieving the RC 2 (WK 2) security class.

In combination with special sound-absorbing glazing of the highest quality, the Trocal 76 AD system guarantees optimal protection against external noise up to 48 dB, while increasing the quality of life.

TROCAL

THE MOST IMPORTANT PARAMETERS

CLASS	DEPTH	CHAMBERS	SEALS
B	76 mm	5	2

* Heat transfer coefficient for the tilt and swing reference window with dimensions of 1230/1480 mm with 4/18/4/18/4 glazing: $U_g=0.5$ with a warm frame.



Thermal transmittance from
 $U_w = 0,73 \text{ W}/(\text{m}^2\text{K})^*$



Installation depth



European CE compliance standard

INVESTMENT SYSTEM WITH HIGHER THERMAL STANDARD

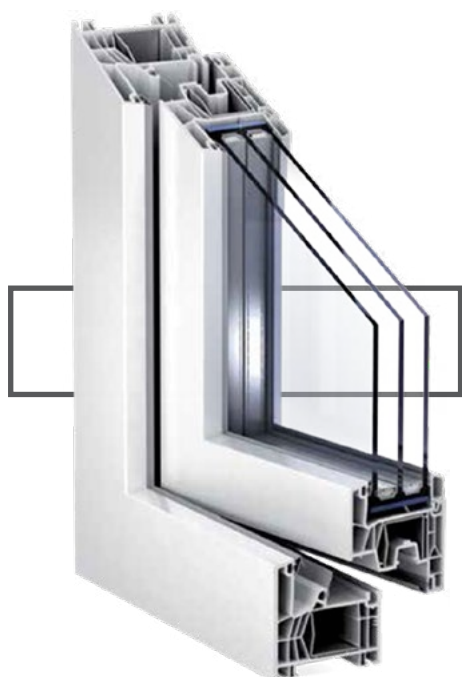

TROCAL 76 MD



A modern plastic window system must meet the highest quality requirements - starting with the appearance through functionality, statics and thermal and acoustic insulation coefficients, to environmental protection and long life. Trocal 76 MD is one system with all the advantages of a modern window.

The Trocal 76 MD system is distinguished by the highest parameters of thermal insulation, which were obtained by, among others, equipping it with an additional inner seal.

Narrow, slender profiles make the glass surface larger. In addition, the attractiveness of the system increases due to the possibility of choosing a wide range of veneers with a wood or uniform structure.

Product properties

Trocal 76 MD window profiles are designed in such a way that it is possible to install special panes in them and special security fittings.

In combination with special sound-absorbing glazing the highest quality Trocal 76 MD system guarantees optimal protection against external sounds up to 48 dB, while increasing the quality of life.



THE MOST IMPORTANT PARAMETERS

CLASS	DEPTH	CHAMBERS	SEALS
B	76 mm	6	3

* Heat transfer coefficient for the tilt and swing reference window with dimensions of 1230/1480 mm with 4/18/4/18/4 glazing; $U_g=0.5$ with a warm frame.



Thermal transmittance from
 $U_w = 0,78 \text{ W}/(\text{m}^2\text{K})^*$



194 mm
Installation depth



European CE
compliance standard

NEW VERSION OF THE MOST POPULAR SYSTEM

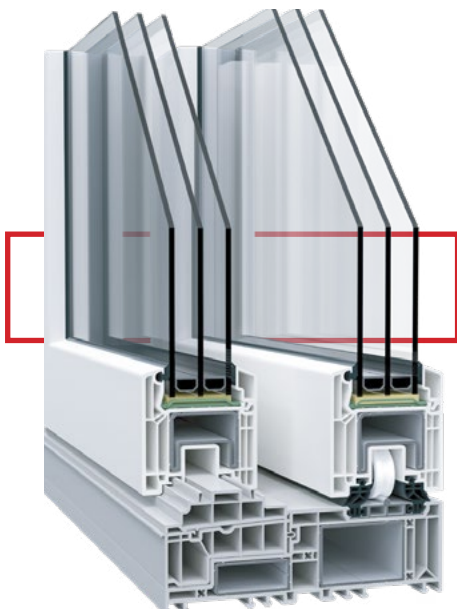

VEKAMOTION 82

The Vekamotion 82 system is the successor to the proven Vekamotion sliding door system. Customer expectations and stringent standards for thermal insulation force designers to work on better, warmer solutions. The result of this work is the Vekamotion 82 system, in which the previously used aluminum threshold was replaced with a thermal break, a plastic threshold, improving the thermal parameters of the window.

This system has also been equipped with special multi-chamber strips masking the mounting holes, which eliminated the need to use plugs, resulting in smoother surfaces of the window. Two-stage sealing system ensures tightness in extreme weather conditions, and the use of profiles from the Vekamotion line makes the Vekamotion 82 lift and slide door form a coherent and harmonious whole.

Product properties

Perfect interior lighting

Energy saving

Thermal insulation, water-tightness and stability of the structure on the highest level.

Security

Opening methods



* Dimensions depend on the size of the window leaf



THE MOST IMPORTANT PARAMETERS

CLASS	SYSTEM PROVIDER	DEPTH	CHAMBERS	SEALS
A	VEKA	194 mm	7 (frame) 5 (leaf)	2

* Heat transfer coefficient for type A reference window with dimensions of 3500/2300 mm with 4/18/4/18/4 glazing: $U_g=0,5$ with a warm frame.





Thermal transmittance from
 $U_w = 0,73 \text{ W}/(\text{m}^2\text{K})^*$



194 mm
Installation depth



European CE complian-
ce standard

MORE LIGHT

VEKAMOTION 82 MAX

Vekamotion 82 Max is an innovative sliding system in which the greatest emphasis has been placed on maximum lighting of the rooms, without sacrificing the functionality of use. Modern architecture appreciates large glazing, allowing for the construction of glass sliding walls that effectively blend into the interior of the house. And this is the Vekamotion 82 Max system. The living room permeates into the garden, and the garden is a guest in the living room.

The system guarantees excellent insulation values, thanks to triple glazing with a glass thickness of up to 54 mm. A two-stage sealing system was used in the area of the sliding sash. The system of external seals ensures the door tightness, even under loads such as hurricane wind and heavy rain. Excellent thermal insulation parameters are complemented by the latest generation of a warm plastic threshold, which, with proper installation, integrates the internal floor with the external terrace.

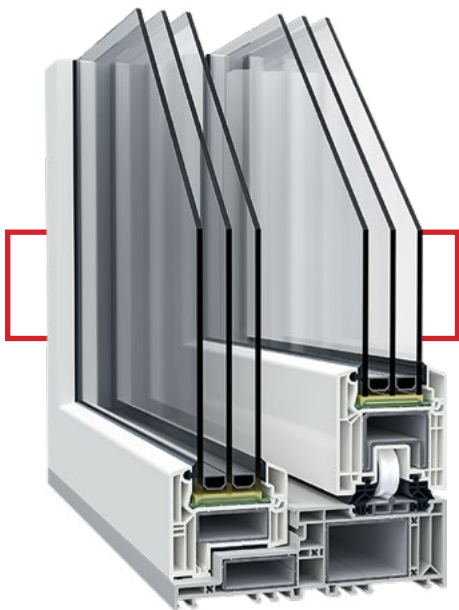

Product properties

Perfect interior lighting thanks to minimizing the height of window profiles and maximizing glazed areas.

Ensuring the harmony of the interior with the external environment.

Thermal insulation, water-tightness and stability of the structure on the highest level.

Ease of use.

Opening methods



* Dimensions depend on the size of the window leaf



THE MOST IMPORTANT PARAMETERS

CLASS	SYSTEM PROVIDER	DEPTH	CHAMBERS	SEALS
A	VEKA	194 mm	7 (frame) 5 (leaf)	2

* Heat transfer coefficient for type A reference window with dimensions of 3500/2300 mm with 4/18/4/18/4 glazing: $U_g=0,5$ with a warm frame.





Thermal transmittance from
 $U_w = 0,79 \text{ W}/(\text{m}^2\text{K})^*$



82 mm
Installation depth



European CE compliance standard

BEST THERMAL PARAMETERS

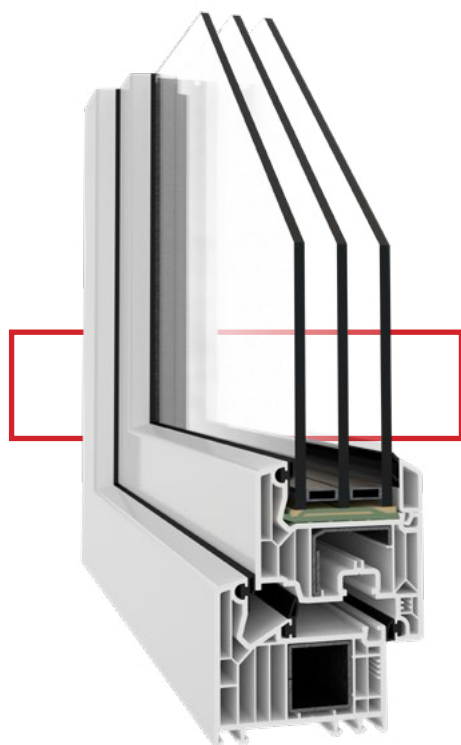

VEKA SOFTLINE 82

Veka Softline 82 is a system of window profiles with a multi-chamber geometry (7 chambers in the frame profile and 6 chambers in the leaf profile) and an installation depth of 82 mm, ensuring energy efficiency at the highest level. Windows built on the basis of this system can be successfully installed in energy-saving and passive houses.

The system is equipped with an additional central seal, which improves the acoustic parameters and thermal protection. It is available in three colors, creating a coherent whole with the core of the profile.

The profiles are adapted to double and triple glazing packages, the width of which is in the range of 24 to 52 mm, which gives the possibility of glazing frames and sashes according to individual needs.

Product properties

Reliable installation of the glass in the profile to a depth of 25 mm limits the condensation of water vapor on the glass and makes it more difficult for unwelcome guests to break in through the window.

Assembly the window frame and leaf starts from 114 mm in height, which translates into an increase in the height of the glazing, and thus better lighting of the rooms.



THE MOST IMPORTANT PARAMETERS

CLASS	SYSTEM PROVIDER	DEPTH	CHAMBERS	SEALS
A	VEKA	82 mm	7 (frame) 6 (leaf)	3

* Heat transfer coefficient for the tilt and swing reference window with dimensions of 1230/1480 mm with 4/18/4/18/4 glazing; $U_g=0,5$ with a warm frame.



Thermal transmittance from
 $U_w = 1,0 \text{ W}/(\text{m}^2\text{K})^*$



Installation depth



European CE compliance standard

WINDOWS WITH A CURVED PROFILE

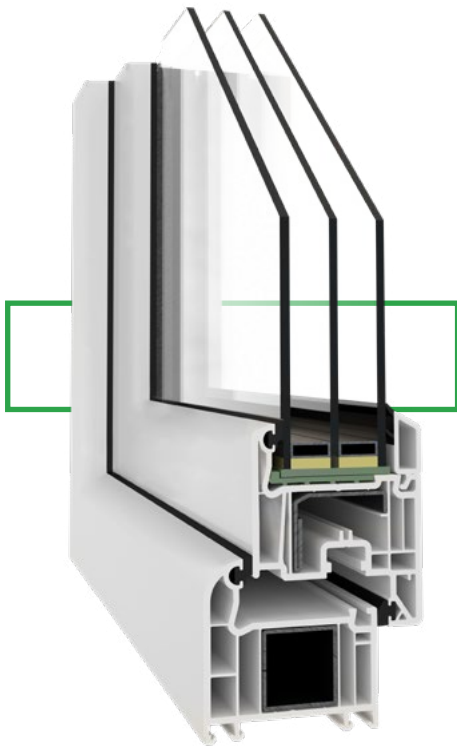

VEKA PERFECTLINE SWING

Veka Perfectline Swing profiles are produced through co-extrusion: the veneer is applied to the colored part of the profile. This solution means that any mechanical damage that may occur over the years of using the window is not visible.

The Veka Perfectline Swing profile, in accordance with the PN-EN 12608 standard, belongs to the highest, profile class A. The customer buying windows in this system can be sure that the external walls of the profile are 3 mm thick (with a tolerance of +/- 0.2 mm). This parameter lies at the basis of excellent thermal and acoustic insulation, high stability, secure mounting of fittings and high security.

The Veka Perfectline Swing system includes profiles for entrance doors, balcony doors and tilt and slide doors.

Product properties

The Veka Perfectline Swing system is a full, 5-chamber system (5 chambers in the frame profile and 5 chambers in the leaf profile) with a depth of 70 mm, ensuring high-level of thermal protection.

The system offers the possibility of using glazing with a thickness of 6 to 40 mm, without the need for additional profiles.

The low total side height of the leaf and frame profiles, amounting to only 118 mm, provides a larger glass area and excellent lighting of the interior.

Fittings in the leaf and frame are mounted through several walls of the profile, guaranteeing their durability and reliability.



THE MOST IMPORTANT PARAMETERS

CLASS	SYSTEM PROVIDER	DEPTH	CHAMBERS	SEALS
A	VEKA	70 mm	5	2

* Heat transfer coefficient for the tilt and swing reference window with dimensions of 1230/1480 mm with 4/18/4/18/4 glazing: $U_g=0,7$ with a warm frame.



Thermal transmittance from
 $U_w = 0,82 \text{ W}/(\text{m}^2\text{K})^*$



76 mm Installation depth



European CE
compliance standard

OPTIMAL PARAMETERS

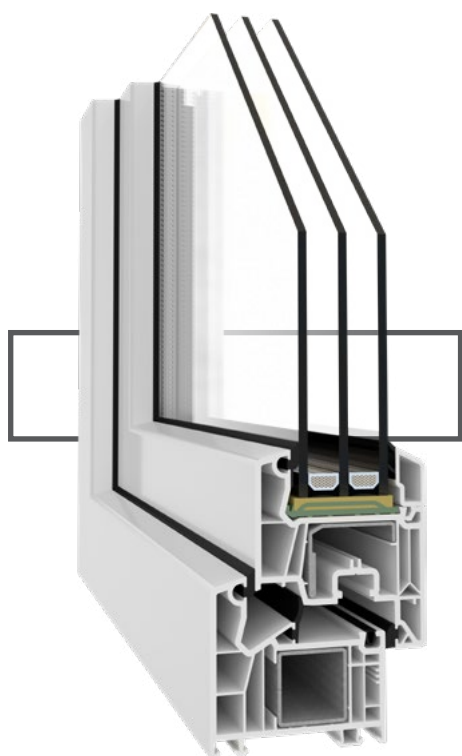

VEKA SOFTLINE 76 MD

Veka Softline 76 MD is a system of window profiles created in the highest class – A, with an installation depth of 76 mm with an additional central seal permanently attached to the frame with a heat transfer coefficient of $U_f=1.1\text{W}/(\text{m}^2\text{K})$. The system of three gaskets provides excellent insulation and protection against negative external factors, such as temperature or noise. It has excellent thermal and mechanical parameters. Together with a properly selected package of insulating glass and fittings, it gives the opportunity to build an energy-saving window with increased security.

A closed profile with 3 mm thick external walls (with a maximum deviation of only $\pm 0.2 \text{ mm}$) meets the requirements of the PN-EN 12608 standard for the highest quality of profiles.

Veka Softline 76 MD profiles have a multi-chamber structure - 5 chambers in the frame profile, 5 chambers in the leaf profile. The assembly of the frame and leaf in the Veka Softline 76 MD system is 122 mm high. However, it may be different in the case of large dimensions of the structure, specific static requirements, specific location in the building and the resulting need to select appropriate profiles.

Product properties

Double and triple pane packages can be used for glazing. The Veka Softline 76 MD profiles allow the installation of glazing units with a thickness of 18 to 48 mm. Thanks to embedding the glazing unit in the profile to a depth of 25 mm, condensation on glass surface is limited. The thermal insulation and security of windows also increases.

Veka Softline 76 MD includes an additional middle seal. The system of leaf seals and the internal one, permanently fixed to the frame, provides excellent insulation and protection against negative external factors, such as temperature or noise.

Veka Softline 76 MD profiles have a minimum of 1.5 mm steel reinforcement, e.g. a closed section $30 \times 30 \times 1.5 \text{ mm}$ placed in the frame. This guarantees adequate stiffness of the window (even with a large area), its durability and safety of use, and also gives the possibility of fixing hardware components and additional profiles in steel.



THE MOST IMPORTANT PARAMETERS

CLASS	SYSTEM PROVIDER	DEPTH	CHAMBERS	SEALS
A	VEKA	76 mm	5	3

* Heat transfer coefficient for the tilt and swing reference window with dimensions of 1230/1480 mm with 4/18/4/18/4 glazing; $U_g=0,7$ with a warm frame.



Thermal transmittance from
 $U_w = 0,85 \text{ W/(m}^2\text{K)}^*$



Installation depth



European CE complian-
ce standard

CLIENT'S CHOICE

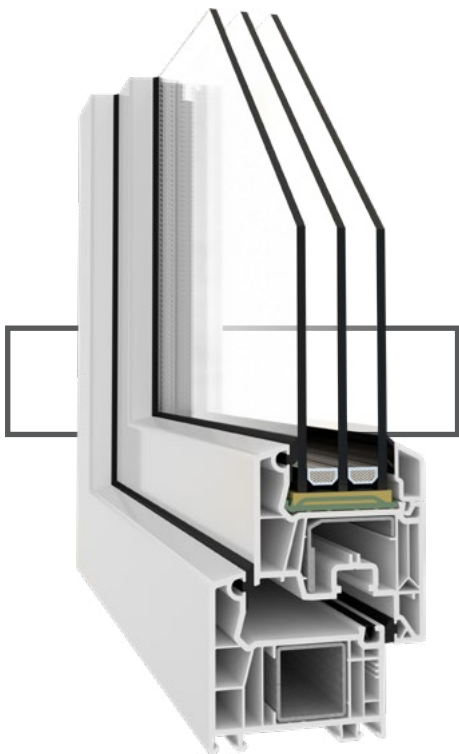

VEKA SOFTLINE 76 AD

Veka Softline 76 AD is a system of window profiles created in the highest class A with a installation depth of 76 mm with high-quality external seals, ensuring very good thermal and acoustic insulation with a heat transfer coefficient of $U_f=1.2\text{W/(m}^2\text{K)}$. It has excellent thermal and mechanical parameters. Together with a properly selected package of insulating glass and fittings, it gives the opportunity to build an energy-saving window with increased security.

A closed profile with external walls 3 mm thick (with a maximum deviation of only ± 0.2 mm) meets the requirements of the PN-EN 12608 standard for the highest quality profiles.

Veka Softline 76 AD profiles have a multi-chamber structure - 5 chambers in the frame profile, 5 chambers in the leaf profile. The assembly of the frame and leaf in the Veka Softline 76 AD system is 122 mm high. However, it may be different in the case of large dimensions of the structure, specific static requirements, specific location in the building and the resulting need to select appropriate profiles.

Product properties

Double- and triple-pane packages can be used for glazing. Veka Softline 76 AD profiles allow you to mount glazing units with a thickness of 18 to 48 mm. Thanks to embedding the glazing unit in the profile to a depth of 25 mm, condensation on glass surface is limited. It also increases thermal insulation and security of windows.

Veka Softline 76 AD profiles have a system of external seals, thanks to which the window achieves high thermal and acoustic insulation.

Veka Softline 76 AD profiles have a minimum of 1.5 mm steel reinforcement, e.g. a closed section $30 \times 30 \times 1.5$ mm placed in the frame. This guarantees adequate stiffness of the window (even with a large area), its durability and safety of use, and also gives the possibility of fixing hardware components and additional profiles in steel.



THE MOST IMPORTANT PARAMETERS

CLASS	SYSTEM PROVIDER	DEPTH	CHAMBERS	SEALS
A	VEKA	76 mm	5	2

* Heat transfer coefficient for the tilt and swing reference window with dimensions of 1230/1480 mm with 4/18/4/18/4 glazing; $U_g=0,7$ with a warm frame.



Thermal transmittance from
 $U_w = 1,0 \text{ W}/(\text{m}^2\text{K})^*$



70 mm
Installation depth



European CE compliance standard

BASIC SOLUTION

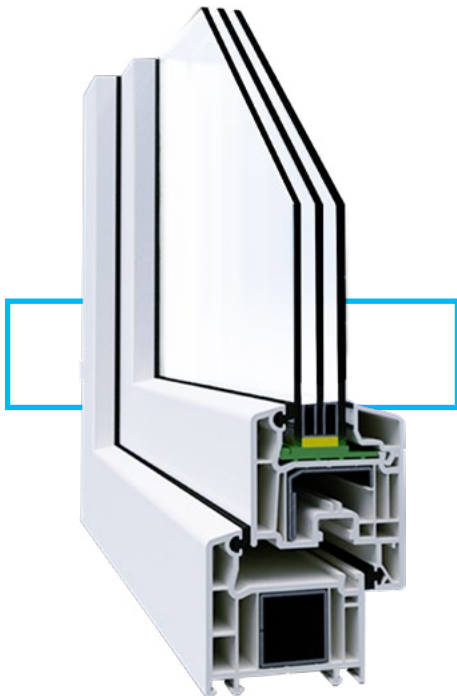

VEKA PERFECTLINE STANDARD

Design with classic optics and balanced proportions. The subdued, neutral appearance and external contours of the Veka Perfectline Standard system match virtually any facade.

The system of two external seals ensures very good tightness, sound insulation and thermal insulation. The surfaces of the seals are oriented with a slope of 15 degrees (identical to the profiles) enabling undisturbed drainage of water and dirt.

In the Veka Perfectline Standard system, proven steel reinforcements are used to ensure excellent statics, long-term preservation of the window function and security. There is a chamber in the frame for closed steel reinforcement, and in the leaf - for double-folded open reinforcement (a unique solution in window technology).

Product properties

Veka Perfectline Standard is a 5-chamber system with a depth of 70 mm, ensuring adequate thermal protection..

The system allows the use of glazing with a thickness of 6 to 40 mm without the need for additional profiles.

Assembling the sash and the window frame is only 118 mm high, thanks to which the glass surface is larger and the rooms are better lit.

The structure of the profiles ensures secure installation of fittings in the leaf and frame. The fixing screws go through several walls of the profile, guaranteeing their permanent and stable arrangement.



THE MOST IMPORTANT PARAMETERS

CLASS	SYSTEM PROVIDER	DEPTH	CHAMBERS	SEALS
A	VEKA	70 mm	5	2

* Heat transfer coefficient for the tilt and swing reference window with dimensions of 1230/1480 mm with 4/18/4/18/4 glazing: $U_g=0,7$ with a warm frame.





ALU LINE

**Innovation
in every detail**

External doors and windows.
Lift and slide windows.
Internal doors and walls.

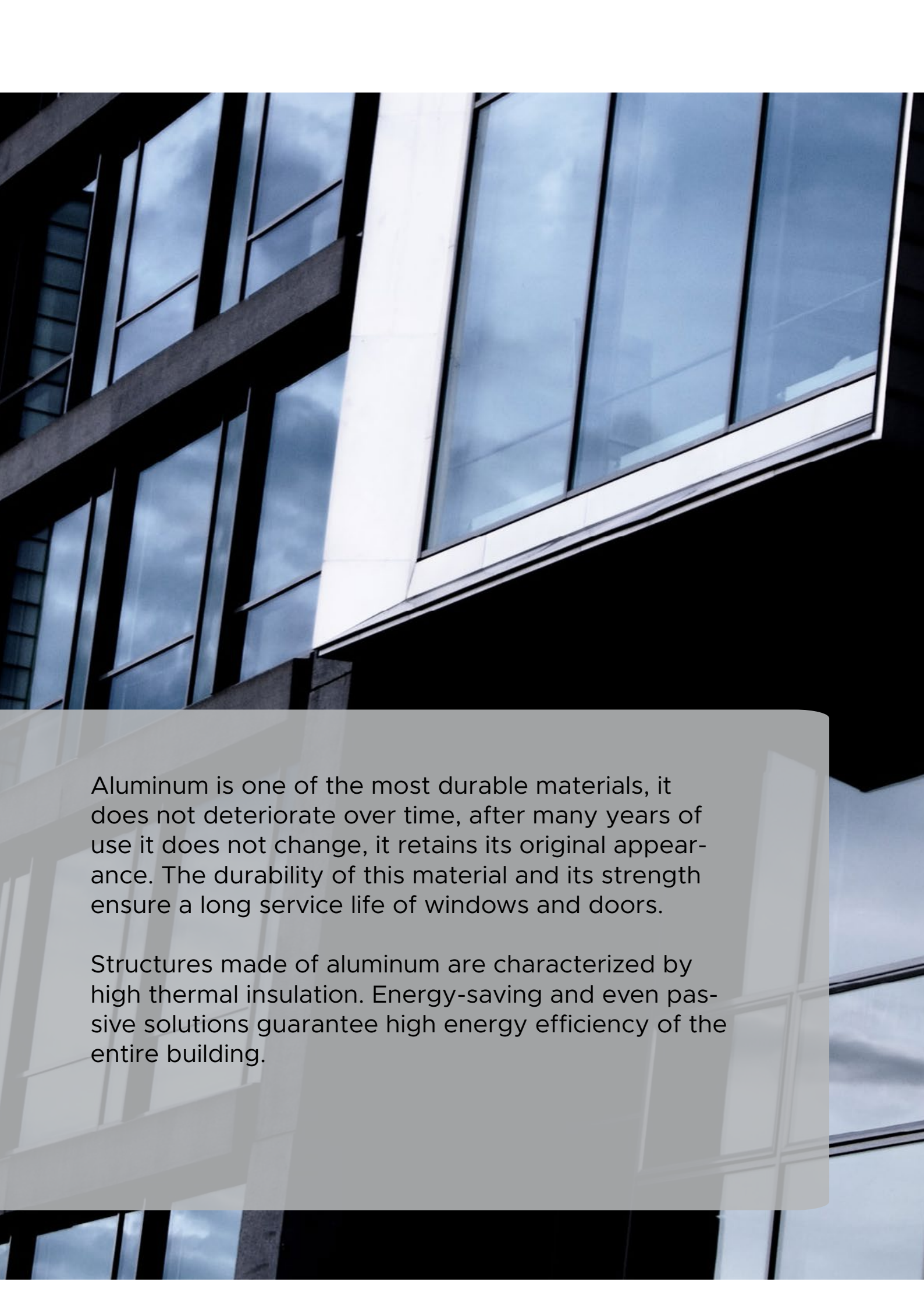

Aluminum is one of the most durable materials, it does not deteriorate over time, after many years of use it does not change, it retains its original appearance. The durability of this material and its strength ensure a long service life of windows and doors.

Structures made of aluminum are characterized by high thermal insulation. Energy-saving and even passive solutions guarantee high energy efficiency of the entire building.



Thermal transmittance from
Ud = 0,80 W/(m²K)*



96 mm
Installation depth



European CE
compliance standard

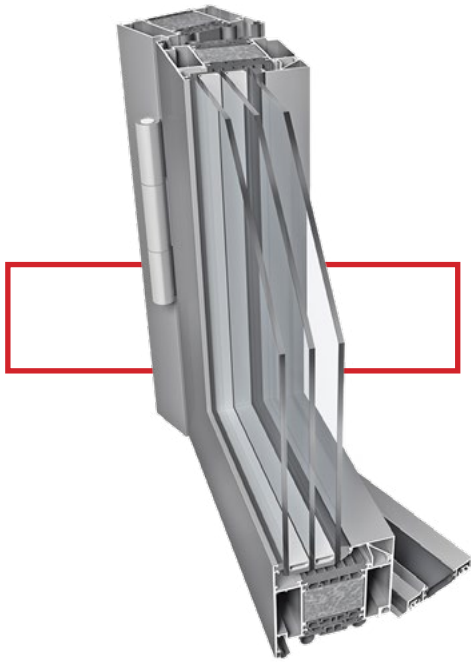

ALULINE PRESTIGE PE96HI DOORS

The system with the highest thermal insulation designed for door structures. Dedicated for the most demanding.

AluLine Prestige door leaves are flush with the frame on both sides, with 50 mm wide thermal breaks.

Thanks to the use of 50 mm wide thermal breaks, very good thermal insulation parameters were obtained, significantly exceeding the current requirements, and the additional central seal improves the parameters of water tightness and air infiltration, which is confirmed by reports obtained at the IFT ROSENHEIM institute.

HIGH THERMAL ISOLATION

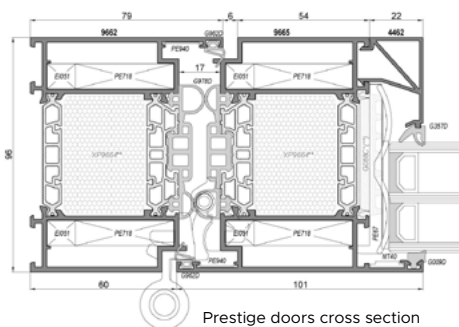

THE MOST IMPORTANT PARAMETERS

WATERPROOF CLASS	AIR PERMEABILITY	FRAME DEPTH	LEAF DEPTH	GLAZING OPTIONS
E750 WG. EN 12208:1999-11	Class 4 in accordance with EN 12207:2016-12	96 mm	96 mm	Glazing packages or non-transparent panels with a thickness of 31 - 66 mm

* The heat transfer coefficient was calculated for the door: 1230 x 2180 mm, Ug = 0,5 W/m²K, double-chamber glass.



Thermal transmittance from **Uw = 0,66 W/(m²K)***



Installation depth



European CE compliance standard

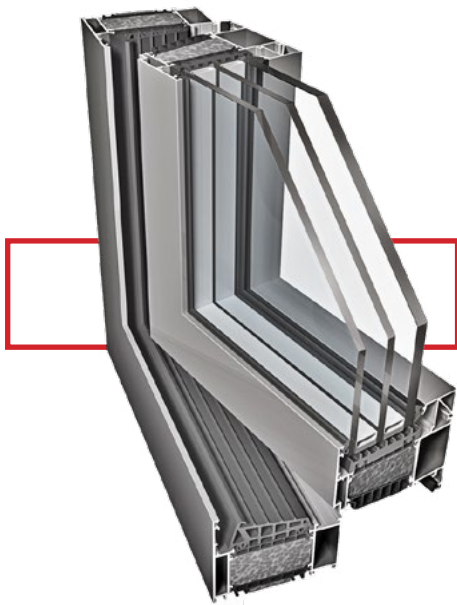

ALULINE PRESTIGE PE96 PASSIVE WINDOWS

The system with the highest thermal insulation, designed for the construction of windows and fixed glazing, where the pane is installed directly in the frame. Dedicated to the most demanding. High thermal insulation is guaranteed by multi-chamber thermal breaks with a width of 62 mm, filled inside with insulating inserts, insulation of the glass chamber and a two-component central gasket.

Possibility of making large-size structures and aligning window sashes with the frame (one plane on the outside)

HIGHEST THERMAL AND TECHNICAL PARAMETERS

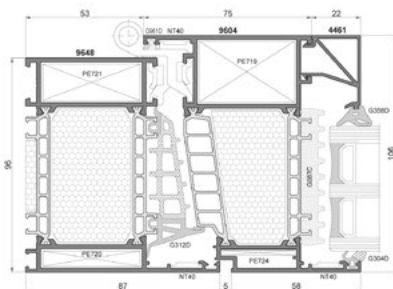

Prestige window cross section



THE MOST IMPORTANT PARAMETERS

WATERPROOF CLASS	AIR PERMEABILITY	RESISTANCE TO WIND LOADS	FRAME DEPTH	LEAF DEPTH	THERMAL BREAK	MAX LEAF SIZE	MAX LEAF WEIGHT	GLAZING OPTIONS
CLASS E1950	CLASS 4	CLASS C5	96 mm	106 mm	62 mm	L 1700 x H 2300 MM	180 KG	Glazing packages or non-transparent panels with a thickness of 39 - 62 mm

* The heat transfer coefficient was calculated for the window: 1480 x 2180 mm, Ug = 0,5 W/m2K, double-chamber glass.



Thermal transmittance from
Ud = 0,89 W/(m²K)*



78 mm
Installation depth



European CE compliance standard

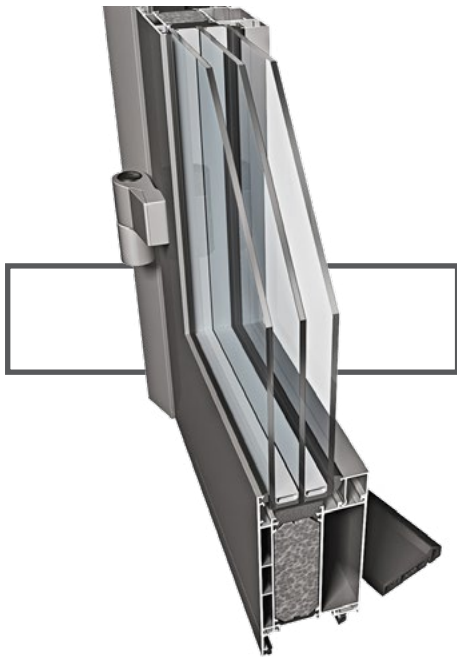

ALULINE OPTIMUM PE78N HI DOORS

A three-chamber thermally insulated system designed for door structures. Easy connection of the door with the windows using specially designed, compatible profiles.

A variant of the Optimum HI system enriched with additional central seals and internal insulating inserts, thanks to which it achieves even better water tightness and Uf thermal insulation parameters.

The seal is attached to a special spacer, the use of special corner plugs to connect the seals in the corners. A new external sealing gasket with a large operating range. Possibility of making large-size structures. Door leaf flush with the frame.

THE WIDEST RANGE OF DOOR STRUCTURE SOLUTIONS

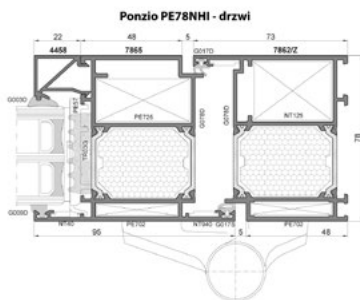

Optimum HI door cross section!



PROCURAL
aluminium systems

THE MOST IMPORTANT PARAMETERS

WATERPROOF CLASS	AIR PERMEABILITY	RESISTANCE TO WIND LOADS	FRAME DEPTH	LEAF DEPTH	THERMAL BREAK	MAX LEAF SIZE	MAX LEAF WEIGHT	GLAZING OPTIONS
CLASS 1050Pa	CLASS 4	CLASS C5	78 mm	78 mm	34 mm	L 1400 x H 3000 mm	280 KG	Glazing packages or non-transparent panels with a thickness of 17 - 61 mm

* The heat transfer coefficient was calculated for the door: 1230 x 2180 mm, Ug = 0,5 W/m2K, double-chamber glass.



Thermal transmittance from $U_w = 0,74 \text{ W}/(\text{m}^2\text{K})^*$



78 mm Installation depth



European CE compliance standard



ALULINE OPTIMUM PE78N HI WINDOWS

Three-chamber thermally insulated system designed for the construction of window structures. Possibility of making many variants of windows, e.g. tilt and turn, outward opening, hidden leaf.

A variant of the Optimum HI system enriched with additional central seals, thanks to which it achieves even better water tightness and U_f thermal insulation parameters.

Window leaf flush with the frame (one plane on the outside). Possibility of making large-size structures as well as curved profiles.

THE WIDEST RANGE OF SOLUTIONS WINDOW CONSTRUCTIONS

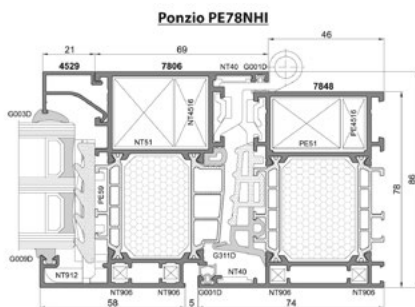

Optimum HI doors cross section



THE MOST IMPORTANT PARAMETERS

WATERPROOF CLASS	AIR PERMEABILITY	RESISTANCE TO WIND LOADS	FRAME DEPTH	LEAF DEPTH	THERMAL BREAK	MAX LEAF SIZE	MAX LEAF WEIGHT	GLAZING OPTIONS
CLASS 1050Pa	CLASS 4	CLASS C5	78 mm	78 mm	34 mm	L 1400 x H 3000 mm	280 KG	Glazing packages or non-transparent panels with a thickness of 17 - 61 mm

*The heat transfer coefficient was calculated for the window: 1480 x 2180 mm, $U_g = 0,5 \text{ W}/\text{m}^2\text{K}$, double-chamber glass.



Thermal transmittance from
Ud = 1,1 W/(m²K)*



78 mm
Installation depth



European CE
compliance standard

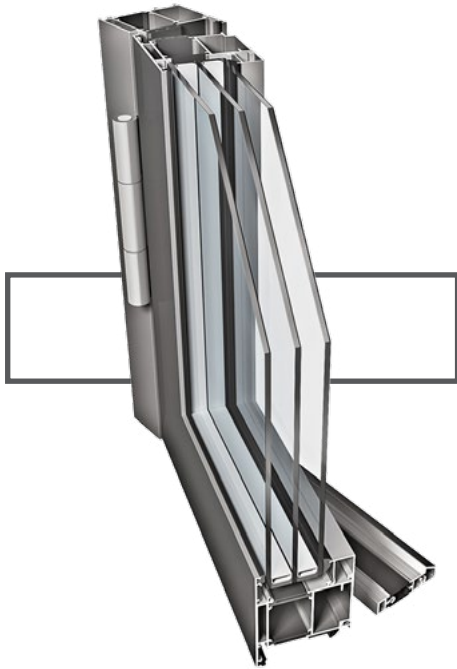

ALULINE OPTIMUM PE78N DOORS

A three-chamber thermally insulated system designed for door structures. Possibility of making large-size structures. Easy connection of the door with the windows using specially designed, compatible profiles.

Door leaf flush with the frame. The Optimum system variant has been present on the market for many years and is considered a proven solution for external doors.

POPULAR AND PROVEN SOLUTIONS

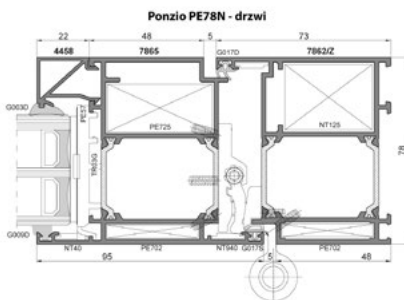

PROCURAL
aluminium systems

THE MOST IMPORTANT PARAMETERS

WATERPROOF CLASS	AIR PERMEABILITY	RESISTANCE TO WIND LOADS	FRAME DEPTH	LEAF DEPTH	THERMAL BREAK	MAX LEAF SIZE	MAX LEAF WEIGHT	GLAZING OPTIONS
CLASS 1050Pa	CLASS 4	CLASS C2/B3	78 mm	78 mm	34 mm	L 1400 x H 3000 mm	280 KG	Glazing packages or non-transparent panels with a thickness of 17 - 61 mm

* The heat transfer coefficient was calculated for the door: 1230 x 2180 mm, Ug = 0,5 W/m2K, double-chamber glass.



Thermal transmittance from $U_w = 0,88 \text{ W}/(\text{m}^2\text{K})^*$



Installation depth



European CE compliance standard



ALULINE OPTIMUM PE78N WINDOWS

A system with high thermal insulation designed for the construction of windows and fixed glazing in the frame. Possibility of making constructions of large dimensions and the possibility of aligning window leaf with the frame (one plane on the outside).

It also has many possibilities to make corner connections. Possibility of creating many variants of windows, e.g. tilt and turn, outward opening, hidden leaf.

CLIENT'S CHOICE

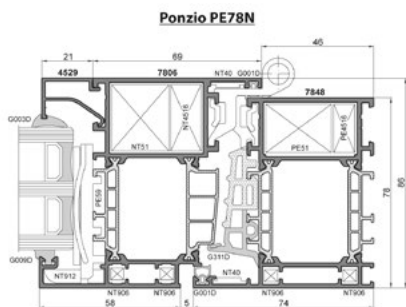

Optimum window cross section



THE MOST IMPORTANT PARAMETERS

WATERPROOF CLASS	AIR PERMEABILITY	RESISTANCE TO WIND LOADS	FRAME DEPTH	LEAF DEPTH	THERMAL BREAK	MAX LEAF SIZE	MAX LEAF WEIGHT	GLAZING OPTIONS
CLASS E1650	CLASS 4	CLASS C5	78 mm	86 mm	42 mm	L 1700 x H 2200 mm; L 1200 x H 3000 mm	200 KG	Glazing packages or non-transparent panels with a thickness of 17 - 61 mm

*The heat transfer coefficient was calculated for the window: 1480 x 2180 mm, $U_g = 0,5 \text{ W}/\text{m}^2\text{K}$, double-chamber glass.



Thermal transmittance from **Uw = 0,92 W/(m²K)***



Installation depth



European CE compliance standard

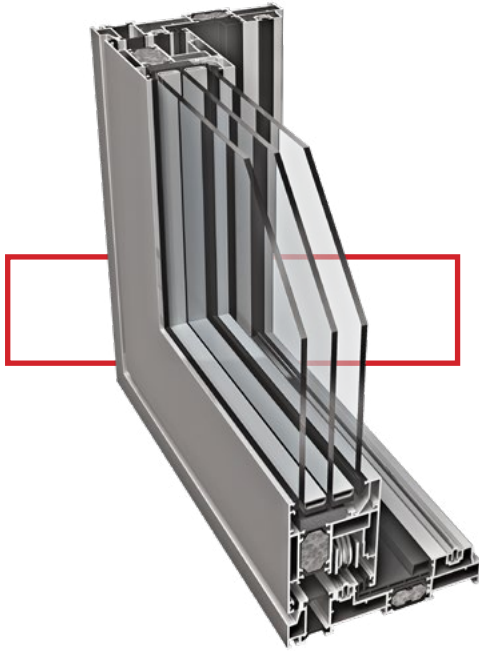

ALU SLIDE SL1600TT HI

The SLIDE lift and slide window system is intended for constructions with particularly high requirements regarding thermal and acoustic insulation, as well as for creating large glazing. Possibility of building a threshold for a more comfortable passage. Moving carts on the guides easily carry up to 400kg weights allowing comfortable usage without the need to use much force.

Opening methods



THE BIGGEST SIZE POSSIBILITIES

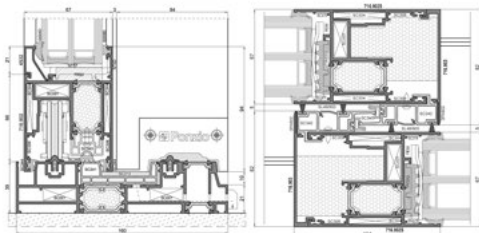

Slide window cross lift and slide window



THE MOST IMPORTANT PARAMETERS

WATERPROOF CLASS	AIR PERMEABILITY	RESISTANCE TO WIND LOADS	FRAME DEPTH	LEAF DEPTH	MAX LEAF SIZE	MAX LEAF WEIGHT	GLAZING OPTIONS
CLASS 9A	CLASS 4	CLASS C3/B5	DOUBLE GUIDE 160/154 mm TRIPLE GUIDE 247/241 mm	67 mm	L 3300 x H 3000 mm; L 2300 x H 3500 mm	300/400 KG	Glazing packages or non-transparent panels with a thickness of 12 - 49 mm

* The heat transfer coefficient was calculated for the window: 3500 x 2400 mm, Ug = 0,5 W/m2K, double-chamber glass.



Profile system without thermal insulation



Installation depth



KOT-2018/0621

ALULINE NORMAL PE50 WALLS

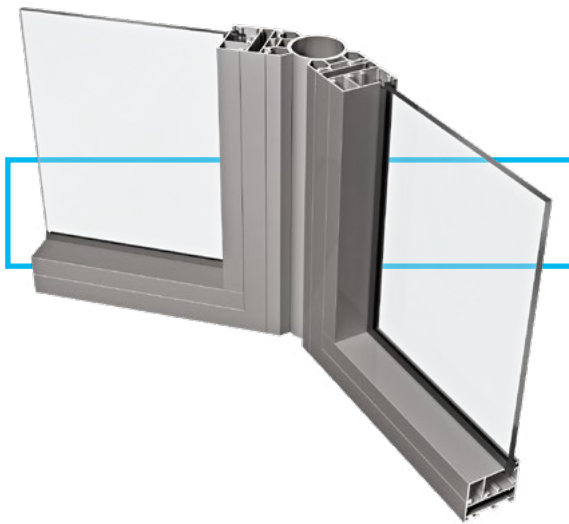

A system of aluminum profiles without thermal insulation designed for internal structures: lightweight walls and glazing as well as operable windows.

The construction depth is 52 mm, the possibility of using: Single glazing, double glazing or non-transparent panels with a thickness of 2-35 mm.

Powder coated with polyester paints that meet the Qualicoat requirements, colors from the RAL palette to choose from; natural anode and colored - Qualanod certified; varnishing in the „color“ of wood - surface finish meets high anti-corrosion requirements.

THE PERFECT SOLUTION FOR INTERNAL DESIGN

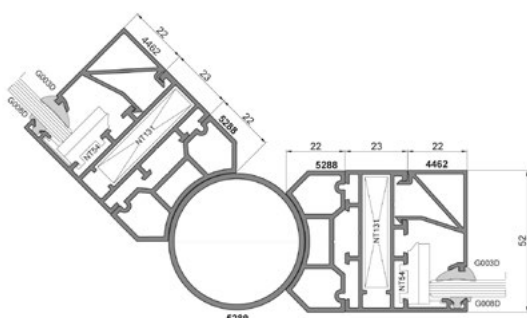

Cross section of the Normal wall



THE MOST IMPORTANT PARAMETERS

MAX SIZE

1500 x 4000mm

FRAME DEPTH

52 mm

GLAZING OPTIONS

Single panes, glazing packages or non-transparent panels with a thickness of 2 - 35 mm



Profile system without thermal insulation



Installation depth



KOT-2018/0621

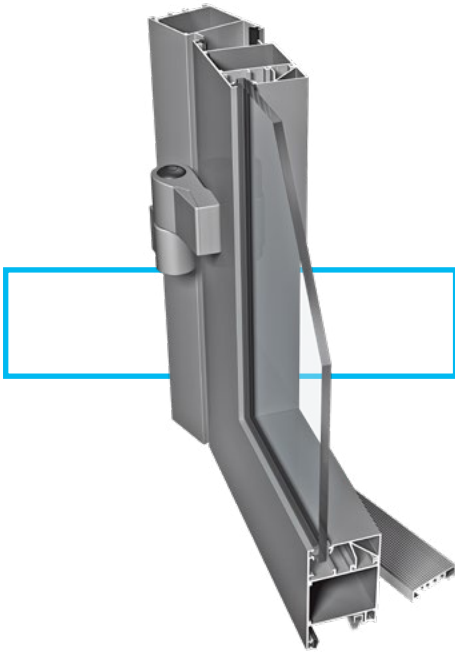

ALULINE NORMAL PE50 DOOR

A system of aluminum profiles without thermal insulation intended for making internal doors that are flush with the door frame on the inside and outside.

Many available variants: with a kick plate or a leaf cut at an angle of 45 degrees, without a threshold or with a threshold. Possibility of making all-glass doors with a pane of ESG tempered glass.

INTERIOR DOOR SYSTEM

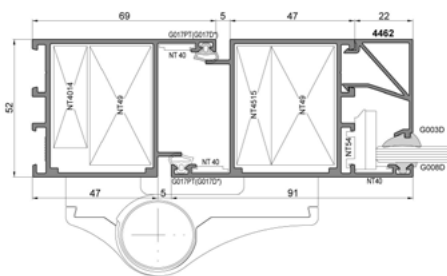

Cross section of the Normal door

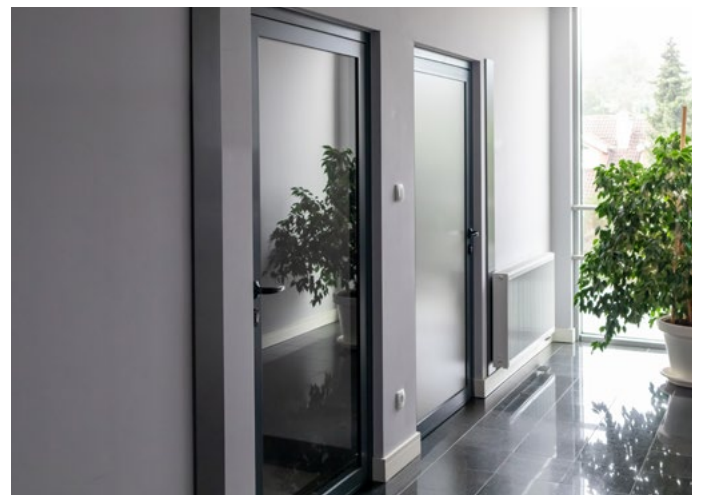

PROCURAL
aluminium systems

THE MOST IMPORTANT PARAMETERS

MAX SIZE

FRAME DEPTH

LEAF DEPTH

GLAZING OPTIONS

Single door: 1350 x 2400 mm
Double door: 2640 x 2455 mm

52 mm

52 mm

Single panes, glazing packages or non-transparent panels with a thickness of 2 - 35 mm





ORNAMENTAL GLASS

Ornamental glass plays a decorative role or protects the privacy of residents by significantly reducing visibility. In our company you will get a wide range of glass to choose from, from classic designs to modern ones.

Transparent (standard)



Altdeutsch brown



Altdeutsch



Abstracto



Flutes vertical matte



Matte/Satin



Delta

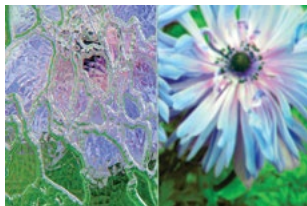

Delta matte



Kura brown



Kathedral

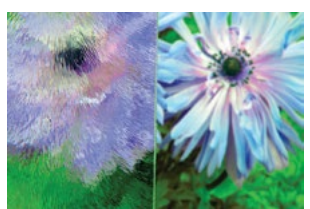

Chinchilla brown

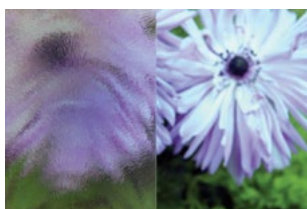

Atlantic

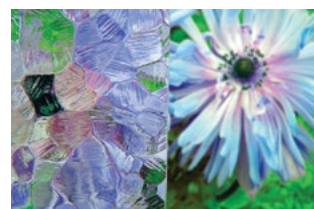

Examples of the most commonly used patterns of ornamental glass. The full offer is available in our showrooms or from our representatives. Colors and patterns are for illustrative purposes only and may differ from the actual ones.

WINDOWS WITH NON-STANDARD SHAPE AND COLOR, EG. CIRCLES, TRAPEZOIDES, ARCHES



Window handle

- S
- W
- BR
- G
- B



Hoppe Atlanta handle

- W BR
- B S
- G T



- S
- W
- BR
- G
- T



- W BR
- B S
- G T

Hoppe Tokyo handle

- W BR
- B S
- G T



Hoppe Toulon handle

- W BR
- B S
- G T



Dublin handle

- W BR
- B S
- G A
- AB G ABS



Hoppe Hamburg DecuForte handle

- W BR
- B S
- G T





Tokyo handle

Available with KISI system



KISI system

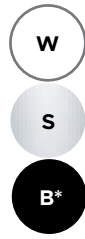

Dublin terrace handle

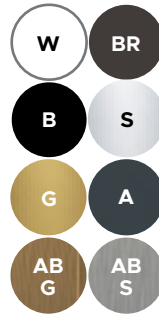

MIX ONLY WITH WHITE INNER COLOR

*black color extends wait time to 1-6 months

Lift and slide PSK system handle



System Legend Slide handle



Victory terrace handle



Lift and slide system HS



MIX ONLY WITH WHITE INNER COLOR

Retro handle



Fittings colors



ALFA pull handle

- 45°
90°
- 80
- 120
- 150
- RAL
- BA A



BETA pull handle

- 45°
90°
- 80
- 120
- 150
- BA A
- SA A



Dublin door handle

- RAL
- BA A
- SA A



Dublin handle tarrace

- RAL
- BA A
- SA A





Dublin lift and slide handle

- RAL
- BA
A
- SA
A



Dublin window handle

- RAL
- BA
A
- SA
A



Jocker door hinges

- RAL
- BA
A
- SA
A



Fittings colors
PVC black collection

- RAL**
RAL 9005
- BA
A**
Brushed anodized aluminum
- SA
A**
Sanded anodizes aluminum

PSK SYSTEM TILT AND SLIDE TERRACE DOORS

The PSK system is an ideal solution for smaller structures. A very interesting alternative to traditional two and three-leaf balcony doors. The advantage of this solution is the elimination of the traditional opening of the sashes inwards, which in the case of sliding doors makes our rooms optically more spacious. This system allows the sash to be tilted, ensuring effective ventilation and free and easy sliding of the sash to the side.

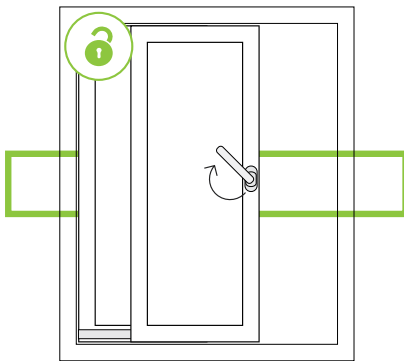

By turning the handle 90°, we open and move the window

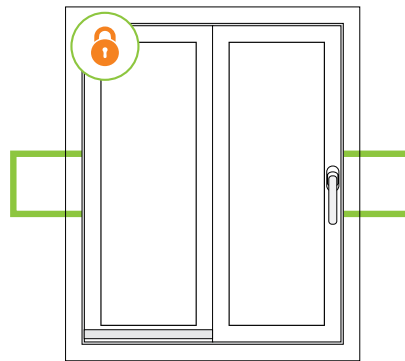

Handle facing down: window in closed position

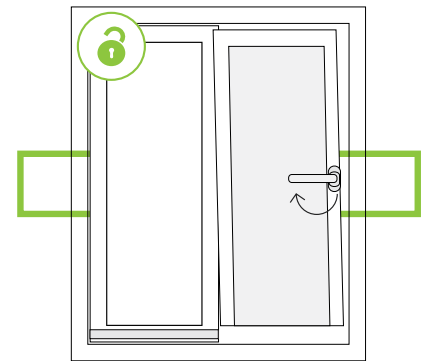

Handle facing up: only tilt

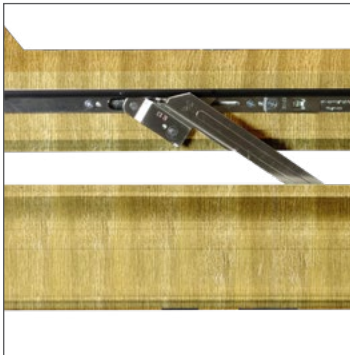



Convenience and comfort of use

**Graduated window tilt**

The amount of exchanged air can be regulated by increasing or decreasing the sash tilt angle to the horizontal tilt position.

**Brake in the handle**

This function allows you to lock the open sash in the desired position. The sash is locked by turning the handle to the closed position.

**Balcony latch with handle**

It enables effective closing of the balcony window after going outside. Handle in colors: white, anthracite, caramel, brown, black, silver.

**Low threshold**

Threshold about 2 cm high. It makes it easier especially for people moving in a wheelchair.

**Air inlets**

AERECO 2MO (Acoustics 33 dB (-1;-1) air vent open 35 dB (-1;-1) closed, Air flow 4-20 m3/h),
AERECO AMA (Acoustics 41 dB (0;0) air vent open 46 dB (-1;-2) closed, Air flow 4-20 m3/h)
AERECO AMD (Acoustics 34 dB (0;1) air vent open 38 dB (0;0) closed, Air flow 7-30 m3/h)
AERECO AMI (Acoustics 34 dB (0;0) air vent open 36 dB (0;0) closed, Air flow 5-25 m3/h)
AERECO AMO (Acoustics 32 dB (-1;1) air vent open 33 dB (0;0) closed, Air flow 6-27 m3/h)

**Humidity-controlled air inlets**

BROOKKVENT Aquavent HY
BROOKKVENT BHY4000 (Acoustics 31 dB (0;1) open vent, Air flow 6-30m3/h)
AERECO EMM
BROOKKVENT SM HY (Acoustics 32 dB (0;1) open vent, 35 dB (0;0), Air flow 8-30m3/h)

**Anti-smog filter for the air inlet**

Compatible with most available window air inlets. The fabric used in the filter has properties that limit the penetration of allergens and smog into the interior of the building. Easy to keep clean.

**Top-mounted air inlet**

The line of Insolio air inlets has a flexible passage between the upper part of the window frame and the lintel. The accessory is available in a standard (E), acoustic (ND) version, with an anti-smog and anti-allergic filter (F) and in a variant combining acoustic and anti-smog parameters (NDF). The air inlets are available in RAL 9016 (white), E and NDF versions - the anti-insect mesh is in the color of raw aluminum. The depth of the channel makes it possible to use this air inlet also above the Slide Line sliding windows.

**Sunscreen windows**

Their use reduces the cost of operation, especially in air-conditioned rooms. It also improves the comfort of use - sunscreen windows block approx. 50-70% of solar energy.

**Soundproof windows**

Thanks to the specialized construction, they effectively suppress sounds of various frequencies. Recommended in buildings located near roads, railways, playgrounds, etc.

**Terrace fittings (double-sided handle + cylinder lock)**

When leaving the balcony window, we can close it from the outside with a handle. It is worth remembering to key the lock cylinder so that unauthorized persons do not gain access to the inside of the building.

**Groove seal**

The hardware groove is part of the frame visible after opening the sash. In general, it is difficult to keep it clean - the solution is to cover it with a flat seal matching the color of the frame.

**Warm inter-pane frames**

They significantly reduce the possibility of condensation on the edges of the glass. Available frame colors: RAL 8003, RAL 8016, RAL 9016, RAL 7035, RAL 7040, RAL 9005

**Warm frame ULTIMATE SWISSPACER**

It provides an impressively low thermal conductivity coefficient at the edge of the insulating glass unit. Thanks to this, appropriately low values of the U_w coefficient for windows and facades are obtained. Available in black RAL 9005.

**Thermo-assembly extension**

Transport extension made of PVC filled with hard polyurethane foam with closed chambers and equipped with a dedicated seal with limited deformation factor.



Convenience and comfort of use



Expanding tape for extensions installed in production

The expansion tape retains its tensile strength even at low temperatures.



Opening limiter

It limits the opening of the sash to the angle of 90°, reducing the risk of damage to the window recess.



Remote tilt

It allows you to operate the window when there is no possibility to directly reach the handle from the floor level.



Slides for window frames

Slides are used for the correct positioning of the window sash in the frame when closing. They prevent frequent window adjustments by guiding the sash to the right place when closing. The slide screwed to the sash is always black, while the slide screwed to the frame is available in white, caramel, anthracite and brown (as in the window core)



Window carrying handles

They facilitate the transport of windows.

Safety



Security fittings in class WK1 or WK2

Additional security latches and a handle with a key, which provide protection against manual breaching, kicking and tools (hammer, screwdriver, etc.).



Magnetic reed switches

A wired proximity sensor that, by connecting it to the alarm system, allows you to determine the state of the window (open/closed).



Reinforced hinges

They extend the life of windows with larger dimensions. They are dedicated to window sashes weighing between 80 and 120 kg.



Safe glazing units (laminated VSG / tempered ESG)

Panes in which glass panes are connected with each other with layers of foil (VSG) or which are subjected to tempering, as a result of which their microstructure changes (ESG). In case of breakage, we reduce the risk of injury. Tempered glass breaks into small, non-sharp pieces when hit, while laminated glass remains in place thanks to the reinforcing foil used.



Security windows

Laminated panes that temporarily prevent a burglar from breaching them. The P4 class pane can successfully replace a metal mesh made of $\varnothing 10$ steel wire with a mesh size of up to 150 mm.



Handles with a button or a key

The rotary movement of the handle, and thus the fittings, is possible after pressing the button on the handle or turning the key. They increase security and make it difficult for the youngest users to maneuver the fitting.



KISI safety handle

Mounted under the plate of the handle. The rotation of the handle is possible by pressing the up/down locking tabs with both hands. The perfect protective barrier for children.



Secure Secuforte handle

SecuForte® technology is a new standard of security. In the closed and tilted state, the window handle is automatically locked - thanks to the lack of connection between the handle and the pin. Available colors are white, brown, black, silver, old gold, titanium.

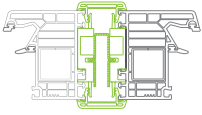

Aesthetics

**Static connectors**

An indispensable element stabilizing large-size glass structures. Effectively absorbs the strain arising, e.g. due to strong gusts of wind.

**Hidden hinges**

A good fit of the hinge elements in the frame of the sash and the frame hides the hinge in a sophisticated way. They enable the appearance of windows and make it easier to keep them clean.

**Inter-pane bars with widths of 8, 18, 26, 45 mm**

Bars as an additional element of the window give our building a unique character. Properly selected, they can refer to the style of old architecture or be an element of modern decoration. Their construction does not hinder the care of the glass, because they are placed inside the glazing unit.

**Glued-on bars with widths of 25, 40, 55 mm**

Bars as an additional element of the window give our building a unique character. Properly selected, they can refer to the style of old architecture or be an element of modern decoration. They are glued on both sides of the glazing, giving the windows a classic dimension.

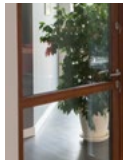
**Vertical and horizontal crossbars**

Elements stabilizing structures, giving them an extraordinary look.

**Ornamental glazing**

Ornamental glass plays a decorative role or protects the privacy of residents by significantly reducing visibility.

**Glass balustrade**

Barrier mounted directly onto the window. A perfect solution when you cannot install a traditional balcony. Made of transparent (standard) tempered glass ESG/VSG 66.2, 13.52 mm thick. Available in colors: RAL 9016, RAL 8017, RAL 9005, RAL 9006, RAL 1036, RAL 7016, RAL 9007.

**Angle connector**

Designed to connect two windows at an angle of 90°.

**Round connector**

Designed to connect two windows at a selected angle.

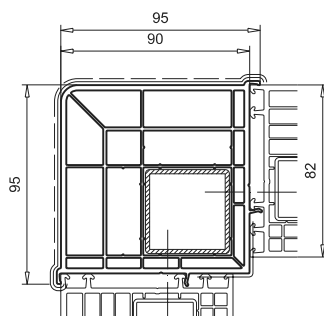
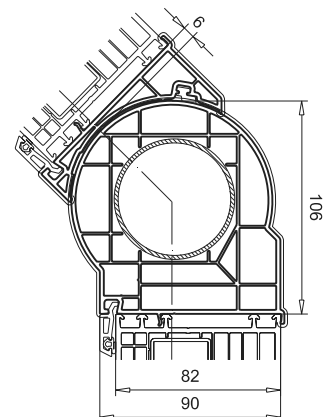
Angle connector**Round connector**



WIKĘD



TEL. 58 678 00 98



UL. WIELKI LAS 19
84-242 LUZINO



WWW.WIKED.PL



luzino@wiked.pl
exportbw@wiked.pl
exportrr@wiked.pl

SALES POINT DETAILS

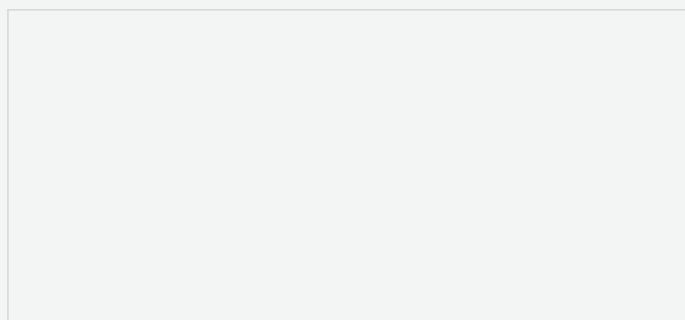

The offer presented in the previous edition of the WIKĘD PVC joinery catalog requires prior verification. The publication does not constitute a commercial offer within the meaning of Art. 66 §1 of the Civil Code and is for information purposes only. The manufacturer reserves the right to make mistakes and changes without prior notice.

Due to the technical limitations of printing and the glazing technology, patterns and colors may differ from the real ones. Photos are for reference only.

